

76.2 cm

194 cm

94.2 cm

- Controlar el contenido de su embalaje antes de proceder al montaje
- No deteriorar el paquete, que le será muy útil para proteger los elementos de golpes y rozaduras durante el montaje.
- Acoplar de seguida el mueble, siguiendo la orden definida por la numeración
- Dado que el mueble ha permanecido encerrado en la caja de cartón desde el momento de su acondicionamiento, es posible que al desembalarlo desprenda a la atmósfera un olor a barniz más o menos pronunciado. Este olor es normal y corresponde a la etapa final de la maduración del acabado del producto que adquirió. Con el fin de evitar que esos olores sean para usted una incomodidad, le aconsejamos dejar el producto en un lugar adecuado y regularmente aireado; abrir por completo las puertas, retirar los cajones y dejarlos aireándose junto al mueble, hasta que tales olores hayan desaparecido.

Fabriqu  en Chine
made in China
fabricado na China
fabricado en China
Hergestellt in China
fabbricato in Cina
Geproduceerd in China

- De inhoud van uw pakket controleren alvorens met de montage te beginnen
- De verpakking niet beschadigen, deze kan heel handig zijn om de onderdelen te beschermen tegen schokken en krassen tijdens de montage
- Zet vervolgens het meubel in elkaar in de volgorde die is bepaald in de nummering
- Het is mogelijk dat zich bij het uitpakken en in elkaar zetten van uw product een min of meer uitgesproken laklucht verspreidt. Dit komt omdat het product na het inpakken in de doos heeft gezeten. Het is normaal dat dit gebeurt, het hoort bij de uiteindelijk afwerking van uw product. Om te voorkomen dat u last heeft van deze lucht, raden we u aan om uw product in een voldoende en regelmatig geventileerde ruimte neer te zetten. Doe daarbij de deurtjes helemaal open en zet de laden naast het meubel neer totdat deze lucht is verdwenen.

- Vor Montage den Inhalt Ihres Paekchens kontrollieren
- Die Verpackung nicht zerst ren, sie wird Ihnen n tzlich sein, um die Teile bei der Montage vor St ssen und Kratzern zu sch tzen.
- Das M bel dann in der Reihenfolge der Nummerierung zusammenbauen
- Da das M belst ck eine gewisse Zeit lang eng verpackt war, ist nicht auszuschlie en, dass sich beim Auspacken und der Montage ein mehr oder minder starker Lackgeruch entwickelt. Diese Geruchsentwicklung nach der Endbearbeitung ist durchaus normal. Damit der Lackgeruch Sie nicht st rt, empfehlen wir Ihnen, Ihren Einrichtungsgegenstand in einen gut und regelm sig gel fteten Raum zu stellen, die Schubl den herauszunehmen und die T ren ganz zu  ffnen, bis sich der Lackgeruch vollst ndig verfl chtigt hat.

- Verificare il contenuto della confezione prima del montaggio
- Non eliminare l'imballo che potr  essere utilizzato per proteggere il prodotto dai danni durante il montaggio
- Montare l'articolo seguendo l'ordine di numerazione
- Per il fatto di essere rimasto chiuso nel cartone dopo l'imballaggio,   possibile che il mobile una volta liberato dal cartone e durante il montaggio sprigioni nell'aria odori di vernice pi  o meno forti. E' un fatto assolutamente normale, e indica la fine della maturazione della finitura del prodotto. Affinch  questi odori non Le creino fastidio, raccomandiamo di collocare il prodotto in un locale adeguatamente e regolarmente aerato, aprendo completamente le porte e depositando i cassetti accanto al mobile fino alla scomparsa degli odori.

- Contr ler le contenu de votre colis avant de proc der au montage
- Ne d t riez pas l'emballage, il vous sera tr s utile pour prot ger les  l ments des coups et rayures pendant le montage
- Assemblez ensuite le meuble en suivant l'ordre d fini par la num rotation
- Du fait de son confinement dans le carton apr s emballage, il est possible qu'au d ballage et au montage votre produit d gage dans l'air des odeurs de vernis, plus ou moins prononc es. Ce d gagement est normal. Il correspond   la fin de la maturation de la finition de votre produit. Afin que ces odeurs ne vous incommode pas, nous vous conseillons de disposer votre produit dans une pi ce convenablement et r guli rement a r e, en ouvrant compl tement les portes et en d posant les tiroirs   c t  du meuble, jusqu'  disparition de ces odeurs.

- Check the contents of your parcel before assembling
- Do not throw away the packing which could be very useful to protect the components from knocks and scratches when assembling
- Next assemble the article following the order of the numbers indicated
- You may notice a smell of varnish when you unpack your item, due to its having been stored in a box since its packaging. This smell can sometimes be quite strong. This is entirely normal, and is simply the result of the final stage in the maturing of the cabinet's finish. In order to avoid any inconvenience that may be caused by such odours, we recommend that you place the item in a well ventilated room, opening all doors, and removing the drawers from the cabinet, until any such odours have dissipated.

- Confira o conte do da sua encomenda antes de iniciar a montagem
- N o danifique a embalagem, poder  ser-lhe  til para proteger os elementos de golpes ou riscos durante a montagem
- Proceda   montagem do m vel seguindo a ordem definida pela numera o
- Devido ao seu encerramento na caixa de cart o ap s o acondicionamento,   poss vel que, no momento da desembalagem e montagem do produto, este lance para o ar um cheiro a verniz, mais ou menos intenso. Esta   uma situa o normal, que corresponde ao final da matura o do acabamento do seu produto. Para que este cheiro n o incomode, aconselhamos-lhe a colocar o produto num compartimento adequado e regularmente arejado, deixando as portas totalmente abertas e colocando as gavetas ao lado do m vel, at  que o referido cheiro desapareca.

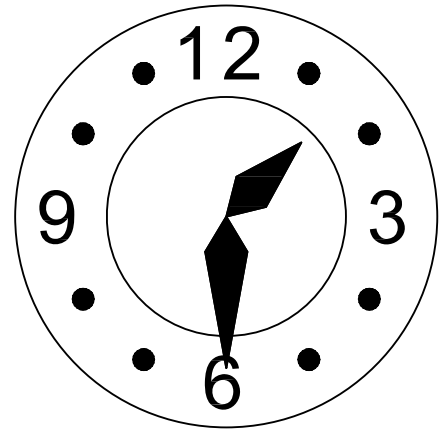
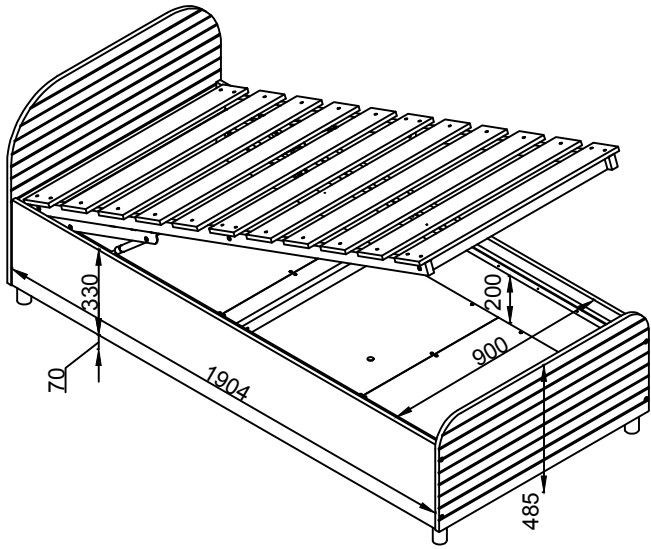

90 Min

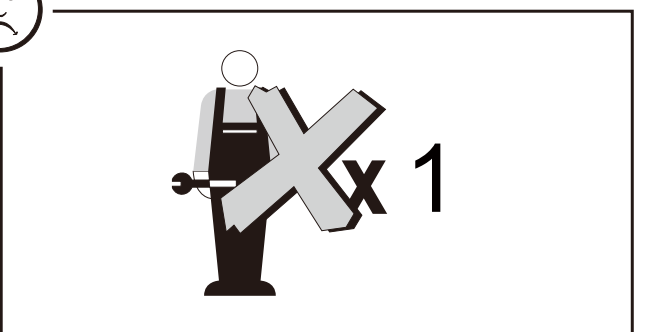
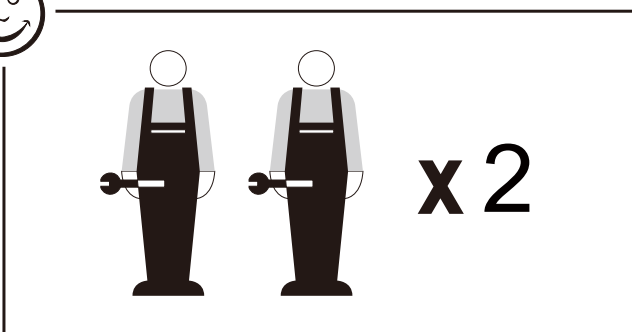
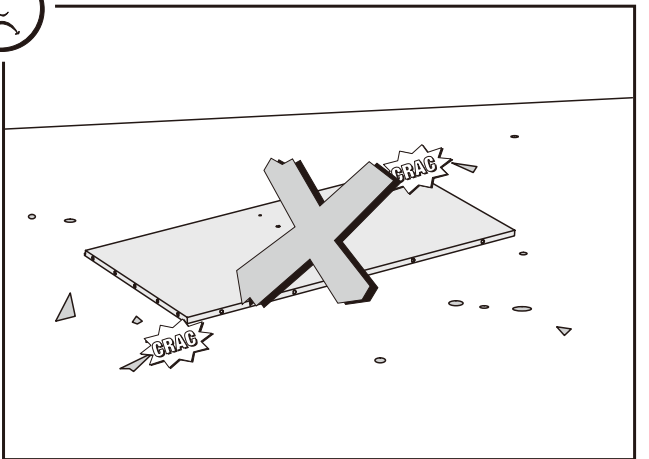
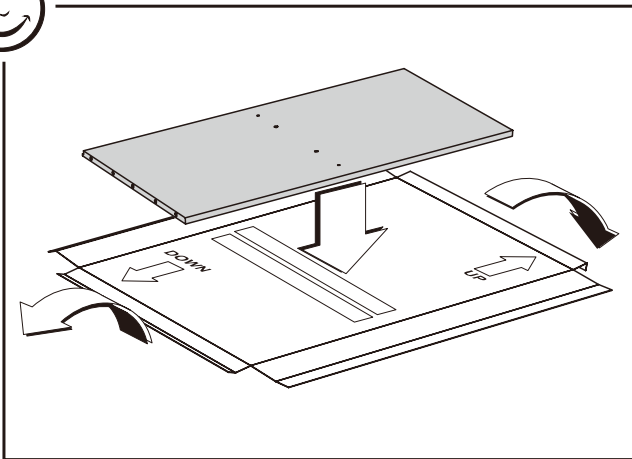
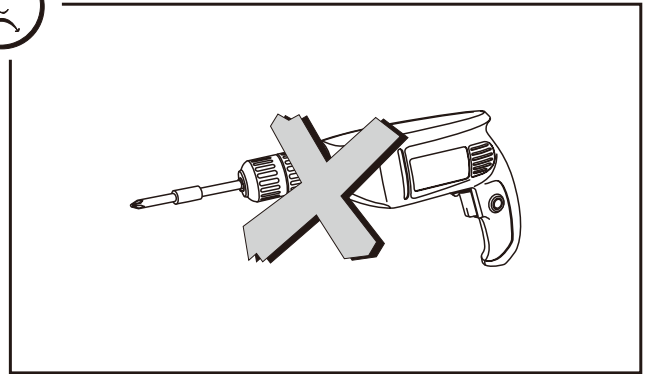
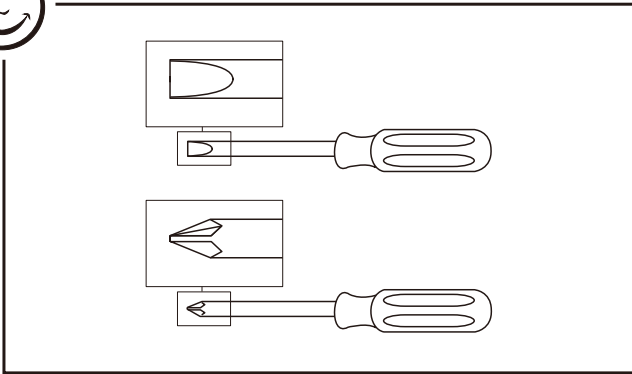

**FR - Notice de montage / EN - Assembly instructions / PT - Instruções de montagem /
ES - Prospecto de montaje / DE - Montageanleitung / IT - Istruzioni di montaggio /
NL - Montagehandleiding**

FR – IMPORTANT! CONSERVER POUR CONSULTATION ULTERIEURE: LIRE ATTENTIVEMENT

- A monter par un adulte. Un adulte doit vérifier le bon assemblage avant l'emploi
- ATTENTION! tenir les vis et petits éléments et sachets hors de portée des enfants
- Bien identifier les éléments avant de commencer le montage
- Ne pas utiliser votre article lorsque l'un de ses éléments est cassé ou manquant
- En cas de problème contactez notre service après-vente
- Toujours suivre les instructions du fabricant
- Entretien: nettoyer avec un chiffon doux et sec. En cas de taches plus grosses, frottez soigneusement avec une éponge légèrement humide et non abrasive
- Ne pas sauter sur le lit
- **ATTENTION ! Poids maximal du matelas (non fourni avec ce produit) : 20 kg**
- **ATTENTION ! Risque de coincement et de cisaillement des mains et des doigts.** Ouvrir et fermer le coffre du lit avec précaution en vérifiant l'absence de toute personne ou tout animal sur le lit et à côté du lit. Ne pas entrer ni jouer, ou laisser toute personne ou tout animal entrer ou jouer, à l'intérieur du coffre du lit

EN – IMPORTANT! KEEP FOR FUTURE REFERENCE: READ CAREFULLY

- To be assembled by an adult. Assembly must be checked by an adult before use
- WARNING! keep all screws, small parts and plastic bags out of the reach of children
- Properly identify all parts before assembling
- Never use your item if any of its parts are broken or missing
- Should any problems arise, please contact our After Sales Service
- Manufacturer's instructions shall be followed at all times
- Care: clean with a soft, dry cloth. In case of larger stains, carefully rub with a slightly damp, non-abrasive sponge
- Do not jump on the bed
- **WARNING ! Maximum weight of mattress (not supplied with this product) : 20 kg**
- **WARNING ! Risk of crushing and of shearing of hands and fingers.** Open and close the chest of the bed with care by making sure of the absence of any person or any animal on the bed or next to the bed. Do not enter neither play, ou allow any person or any animal enter or play, inside the chest of the bed.

PT – IMPORTANTE! GUARDE PARA CONSULTA POSTERIOR: LER ESTAS INSTRUÇÕES CUIDADOSAMENTE

- A ser montado por um adulto. Um adulto deve verificar a boa montagem antes da utilização
- ATENÇÃO! mantenha os parafusos, acessórios pequenos e saco de plástico fora do alcance das crianças
- Identifique bem os acessórios antes de começar a montagem
- Não utilizar o artigo se um dos elementos está em falta ou danificado
- Para qualquer esclarecimento, contacte os nossos serviços através do telefone
- As instruções do fabricante devem ser sempre cumpridas
- Manutenção: limpe com um pano macio e seco. Em caso de manchas maiores, esfregue cuidadosamente com uma esponja ligeiramente húmida e não abrasiva
- Não salte na cama
- **ATENÇÃO! Peso máximo do colchão (não fornecido com este produto) : 20 kg**

- **ATENÇÃO! Risco de esmagamento e corte das mãos e dos dedos.** Abrir e fechar a caixa da cama com precaução, certificando-se de que não há nenhuma pessoa ou nenhum animal sobre a cama ou próximo da mesma. Não entrar, nem brincar, ou permitir que qualquer pessoa ou animal entre ou brinque, no interior da caixa da cama.

ES – IMPORTANTE! CONSERVAR PARA FUTURAS CONSULTAS: LEER DETENIDAMENTE

- A montar por un adulto. Un adulto debe comprobar el buen montaje antes de la utilización
- ¡ADVERTENCIA! mantener los tornillos, los pequeños elementos y bolsitas fuera del alcance de los niños
- Identificar debidamente los elementos antes de empezar el montaje
- No utilizar este artículo si uno de los elementos falta o esta roto
- Si tiene problemas, contactar nuestro servicio postventa
- Deben seguirse siempre las instrucciones del fabricante Cuidados: limpiar con un paño suave y seco. En caso de manchas grandes, frotar con cuidado utilizando una esponja húmeda no abrasiva
- No saltar sobre la cama
- **¡ADVERTENCIA! Peso máximo del colchón (no se incluye con este producto) : 20 kg**
- **¡ADVERTENCIA! Riesgo de aplastamiento y corte de las manos y los dedos.** Abrir y cerrar el arcón de la cama con cuidado, asegurándose de que no haya ninguna persona o animal sobre la cama o junto a ella. No entrar al interior del arcón de la cama ni jugar dentro del mismo, y no dejar que ninguna persona o animal entre o juegue dentro del arcón de la cama.

DE – WICHTIG! FÜR SPÄTERE BEZUGNAHME AUFBEWAHREN: SORGFÄLTIG LESEN

- Von einem Erwachsenen zu montieren. Die korrekte Montage muss vor Gebrauch von einem Erwachsenen geprüft werden
- ACHTUNG! die Schrauben und kleinen Teile ausserhalb der Reichweite von Kindern lagern
- Vor Montagebeginn alle Teile identifizieren
- Ihren Artikel nicht benutzen, wenn eines seiner Bestandteile beschädigt ist oder fehlt
- Im Problemfall Ihren Kundendienst anrufen
- Stets die Herstelleranweisungen beachten
- Wartung: Mit einem weichen, trockenen Tuch reinigen. Bei größeren Flecken vorsichtig mit einem leicht feuchten, nicht scheuernden Schwamm abreiben
- Nicht auf dem Bett springen
- **ACHTUNG! Maximale gewicht der matratze (nicht im Lieferumfang dieses Produktes enthalten) : 20 kg**
- **ACHTUNG! Gefahr des Quetschens und Einklemmens der Hände und Finger.** Vorsichtig öffnen und schließen das Bettkasten und dabei sicherstellen, dass sich weder Personen noch Tiere auf oder neben dem Bett befinden. Nicht hineinsteigen oder im Bettkasten spielen oder Personen oder Tiere hineinklettern oder im Bettkasten spielen lassen.

IT - IMPORTANTE! CONSERVARE QUESTE INFORMAZIONI PER ULTERIORI CONSULTAZIONI: LEGGI ATTENTAMENTE





- Il montaggio deve essere eseguito da un adulto. Un adulto dovrà verificare il corretto montaggio prima dell'uso
- ATTENZIONE! tenere le viti ed i componenti di piccole dimensioni lontano dalla portata dei bambini
- Controllare i pezzi prima del montaggio
- L'articolo non deve essere utilizzato in caso di elementi mancanti o danneggiati
- In caso di necessità contattare il nostro servizio post-vendita
- Seguire sempre le istruzioni del costruttore

- Manutenzione: pulire con un panno morbido e asciutto. Per le macchine più grandi, strofinare accuratamente con una spugna leggermente umida e non abrasiva
- Non saltare sul letto
- **ATTENZIONE! Peso massimo del materasso (non fornito con questo prodotto) : 20 kg**
- **ATTENZIONE! Rischio di schiacciamento e taglio delle mani e delle dita.** Aprire e chiudere il vano del letto con attenzione verificando che non siano presenti persone o animali sopra o accanto al letto. Non entrare né giocare e non fare entrare persone o animali all'interno del vano del letto.

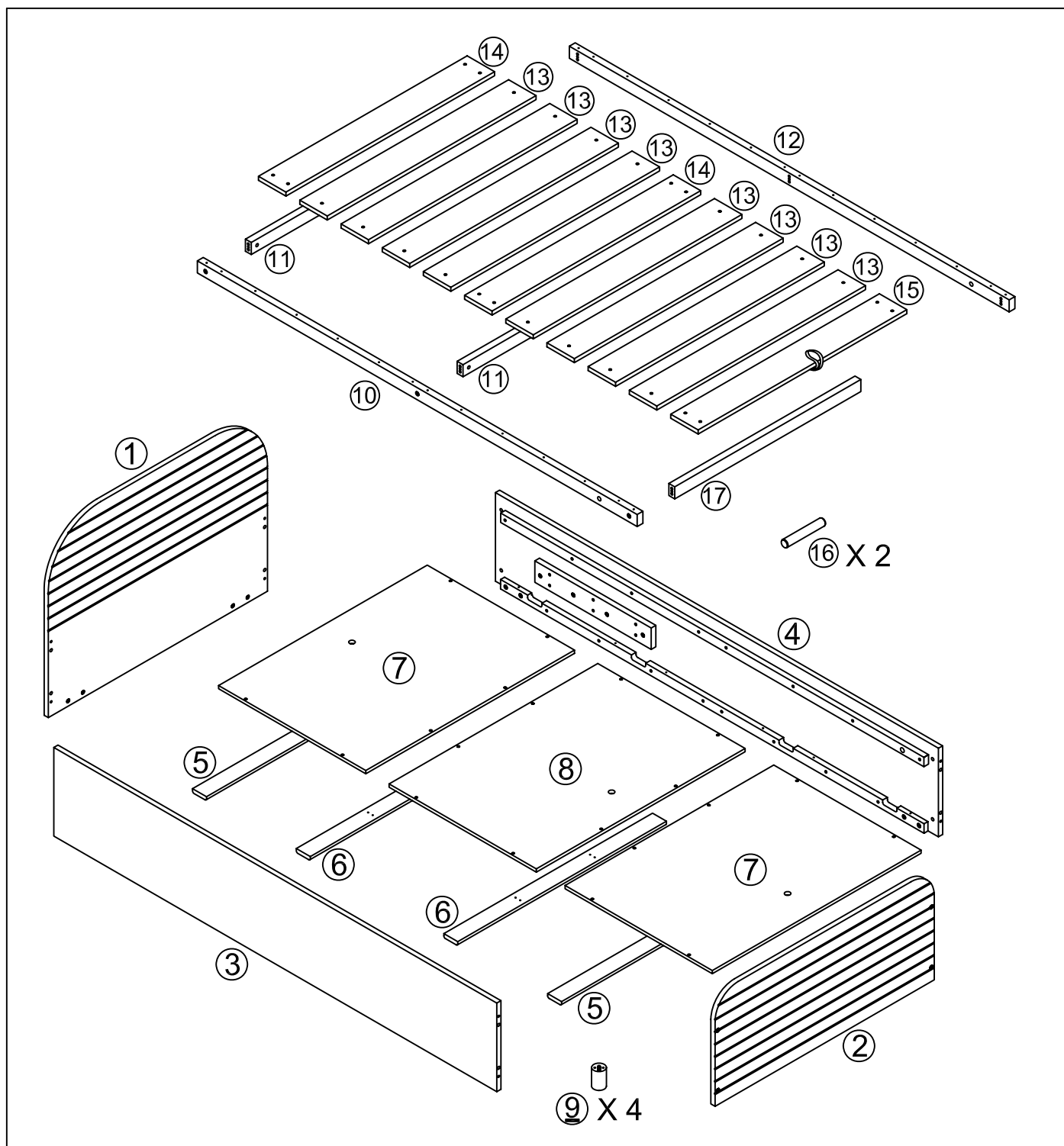
NL - BELANGRIJK! BEWAAR VOOR LATERE RAADPLEGING: LEES AANDACHTIG

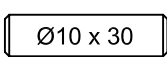
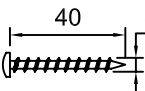
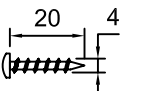
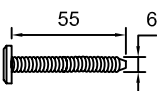
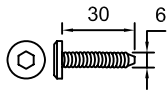
- Moet door een volwassene worden gemonteerd. Voor gebruik moet een volwassene controleren dat het product goed in elkaar is gezet
- **WAARSCHUWING!** schroeven en kleine elementen en zakjes buiten bereik van kinderen houden
- De elementen goed identificeren alvorens met de montage te beginnen
- Uw artikel niet gebruiken wanneer een van de onderdelen kapot is of ontbreekt
- Neem bij problemen contact op met onze klantenservice
- Volg altijd de instructies van de fabrikant
- Onderhoud: maak schoon met een zachte en droge doek. In geval van grotere vlekken, veeg voorzichtig schoon met een licht bevochtigde en niet-schurende spons
- Niet springen op het bed
- **WAARSCHUWING! Maximum gewicht van matras (niet met dit product meegeleverd) : 20 kg**
- **WAARSCHUWING! Risico op het pletten en beknellen van de handen en vingers.** Open en sluit het bed voorzichtig en zorg ervoor dat er zich geen persoon of dier op het bed of naast het bed bevindt. Betreed of speel niet in het bedframe of zorg dat er geen andere persoon of dier het bedframe betreedt of erin speelt.

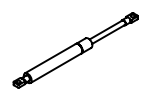
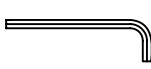
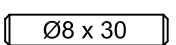
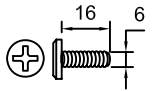
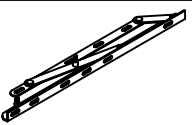
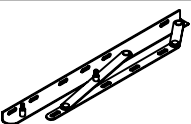
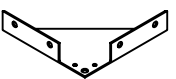
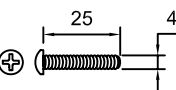



A X 8 	B X 28 	C X 20 	D X 14 
E X 8 	F X 8 	G X 14 	H X 2 
I X 1 	J X 12 	K X 28 	L X 1 
M X 1 	N X 4 	O X 8 	P X 1 

1

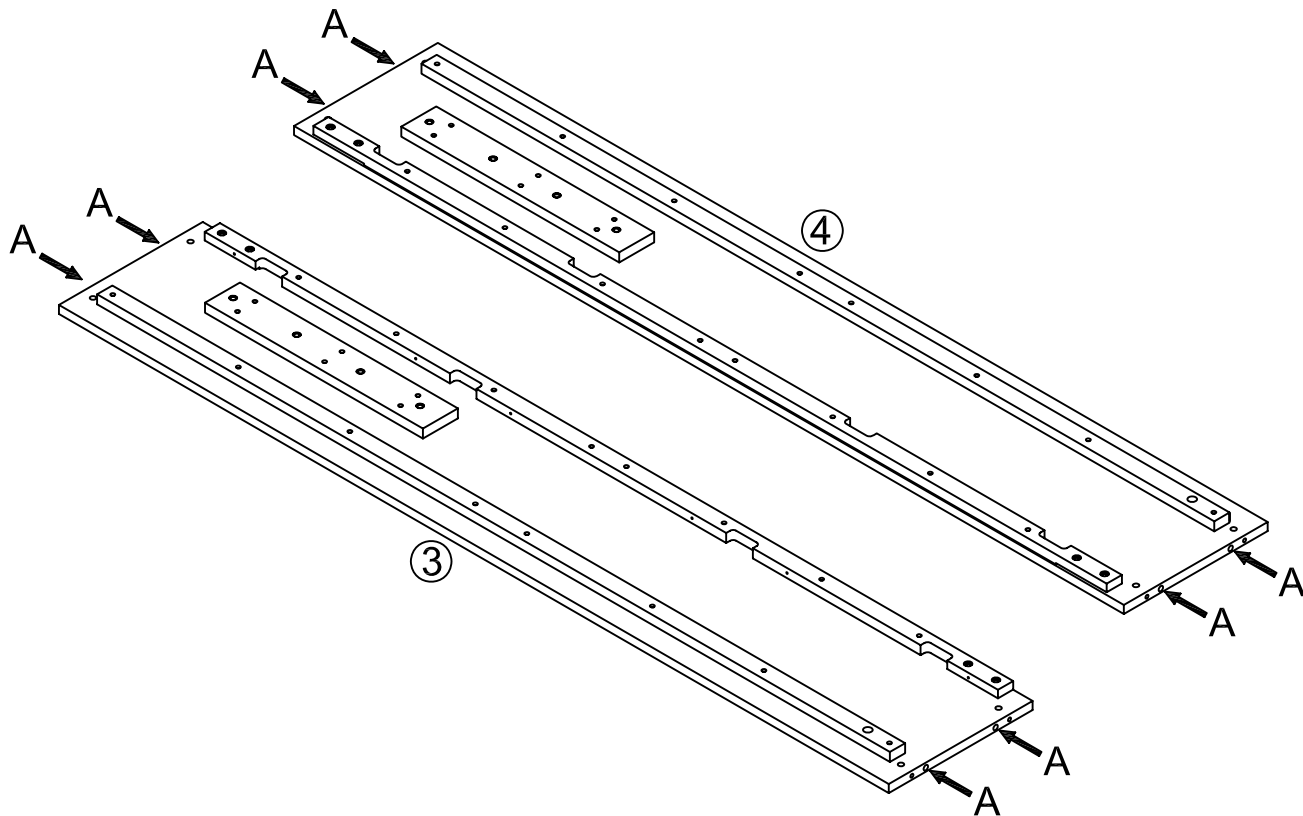
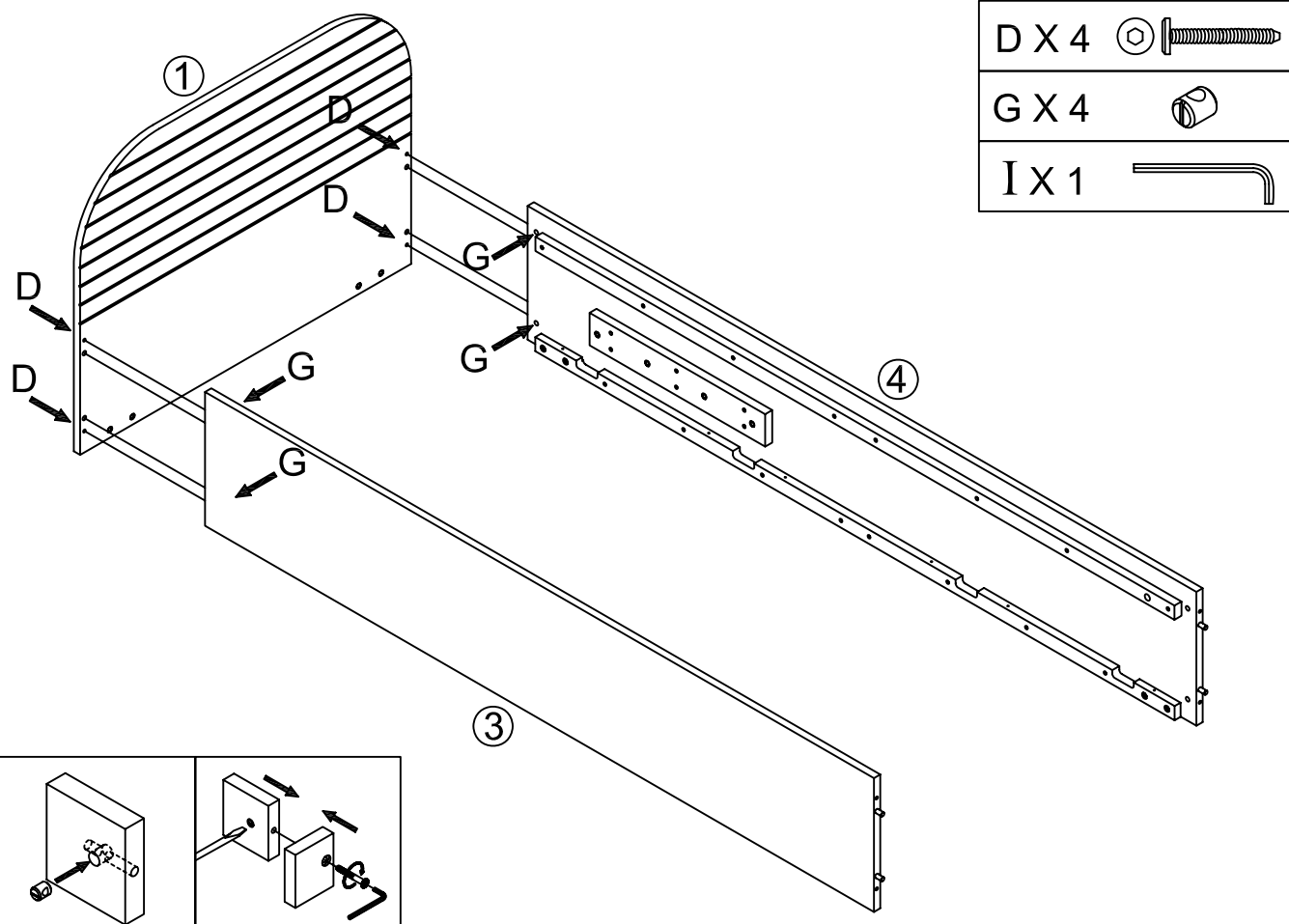
A X 8



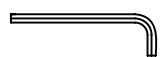

**2**

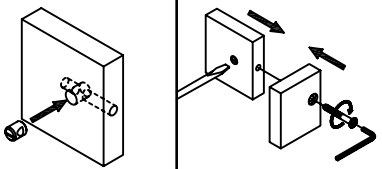
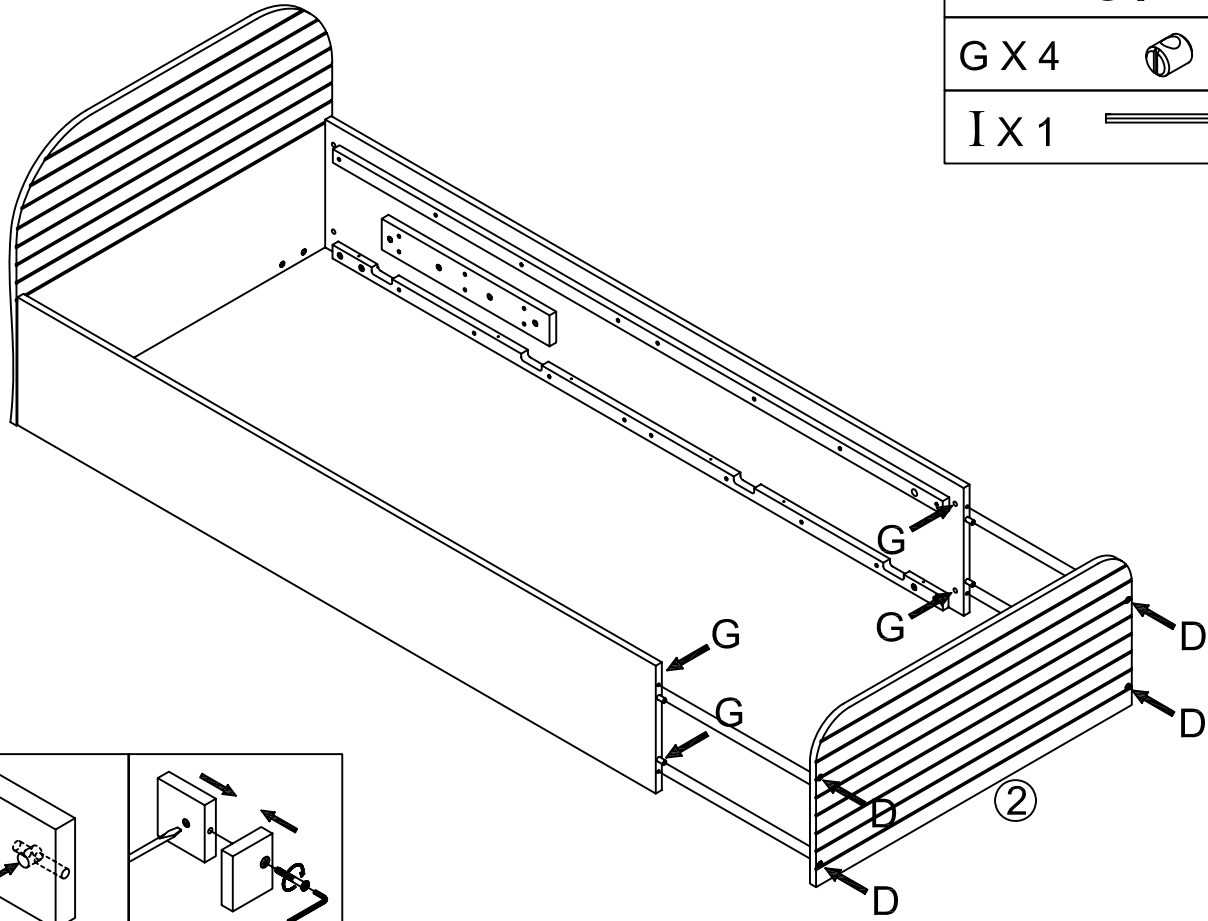
3

DX 4	
GX 4	
IX 1	



4

FX 4		NX 4		OX 8		PX 1	
------	---	------	---	------	--	------	---

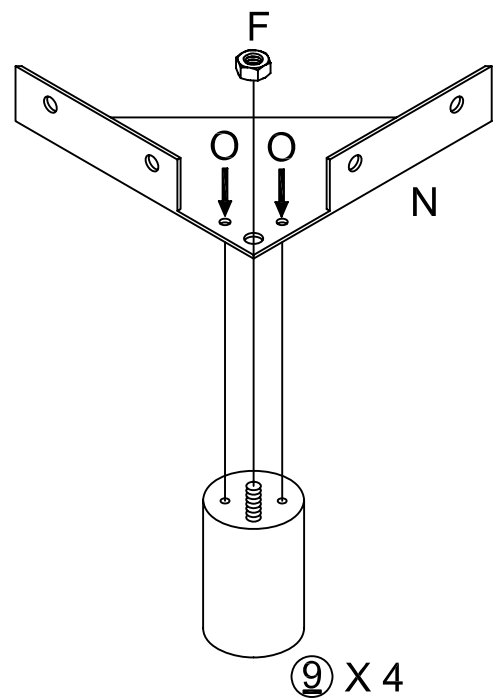

5

EX 8	
KX 8	
IX 1	

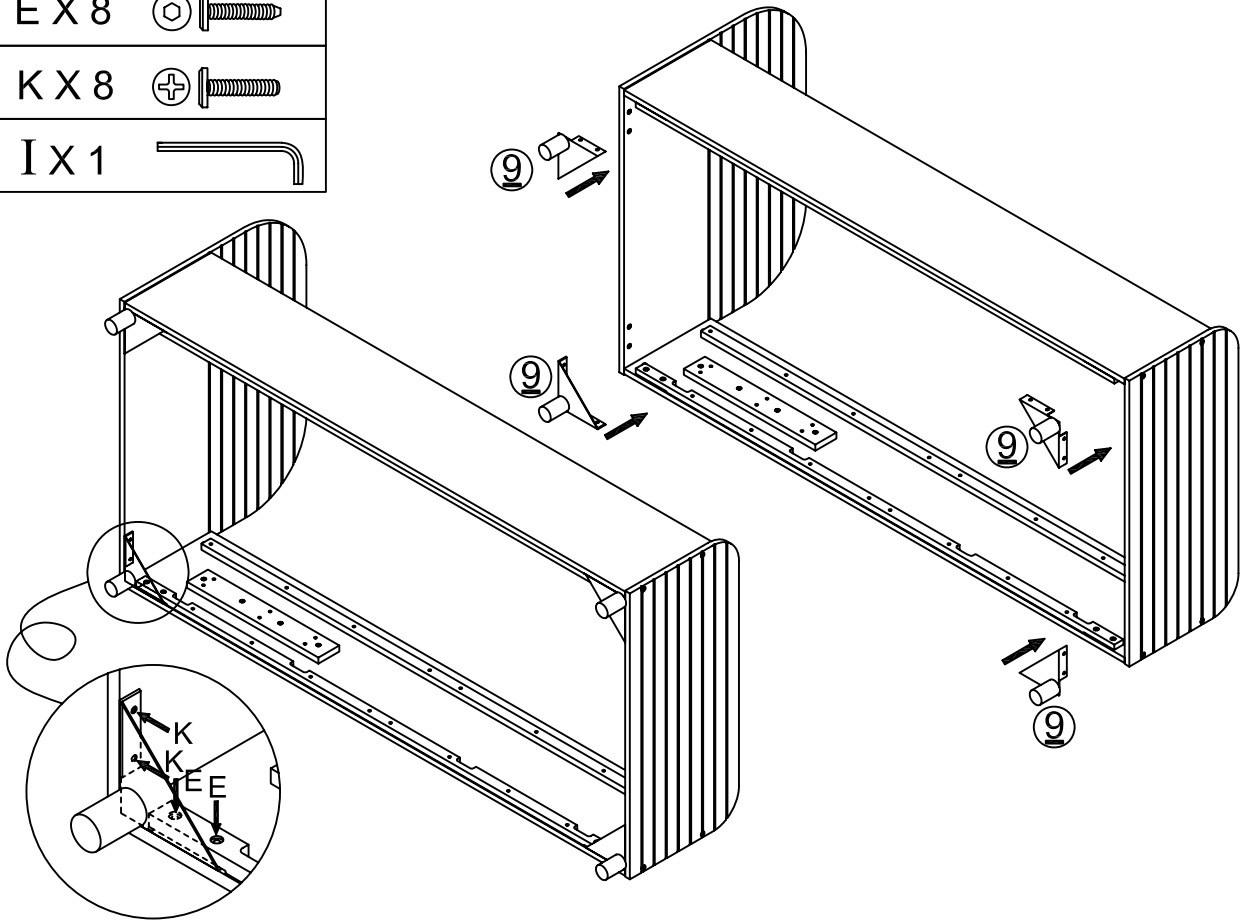

6

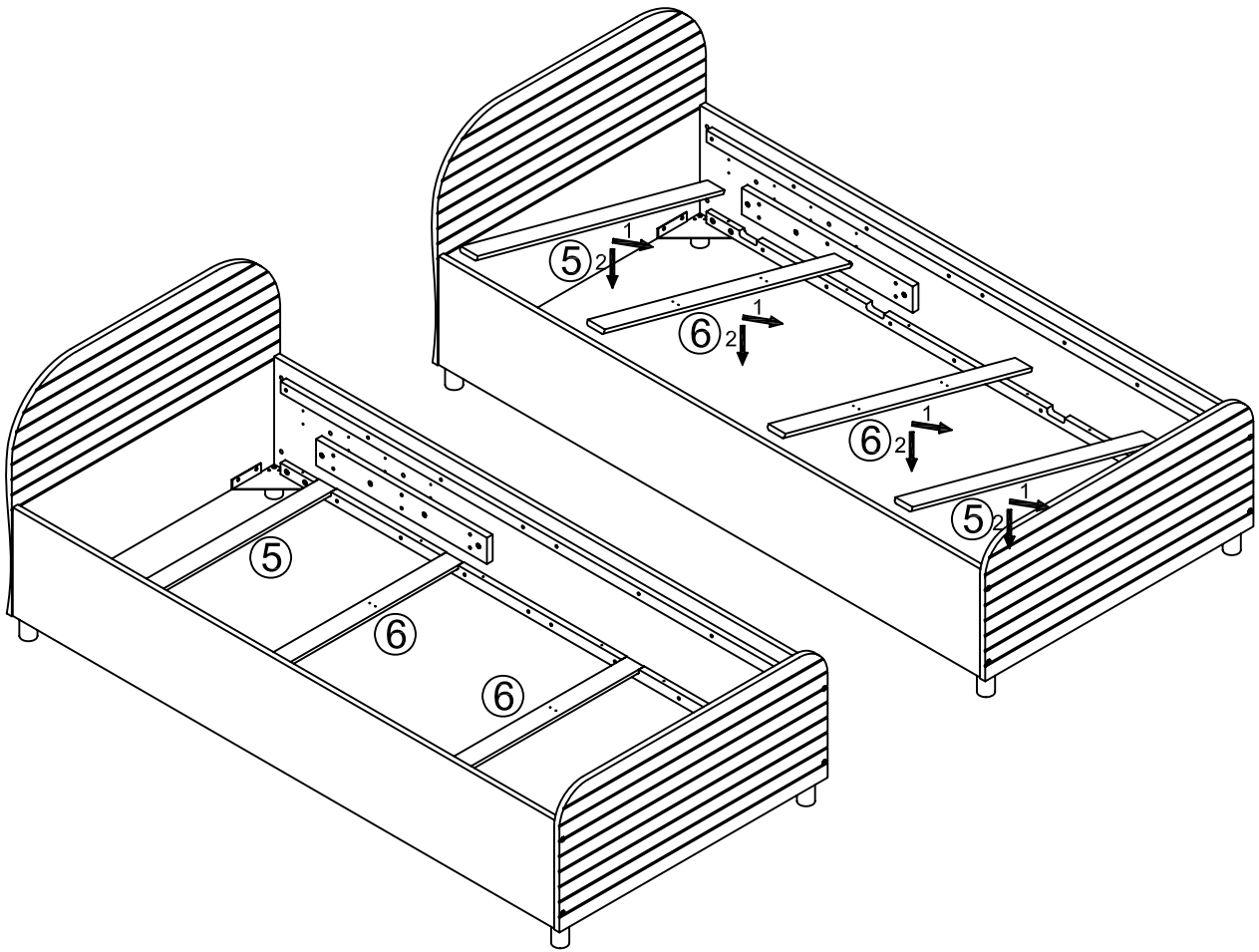

7

C X 20 

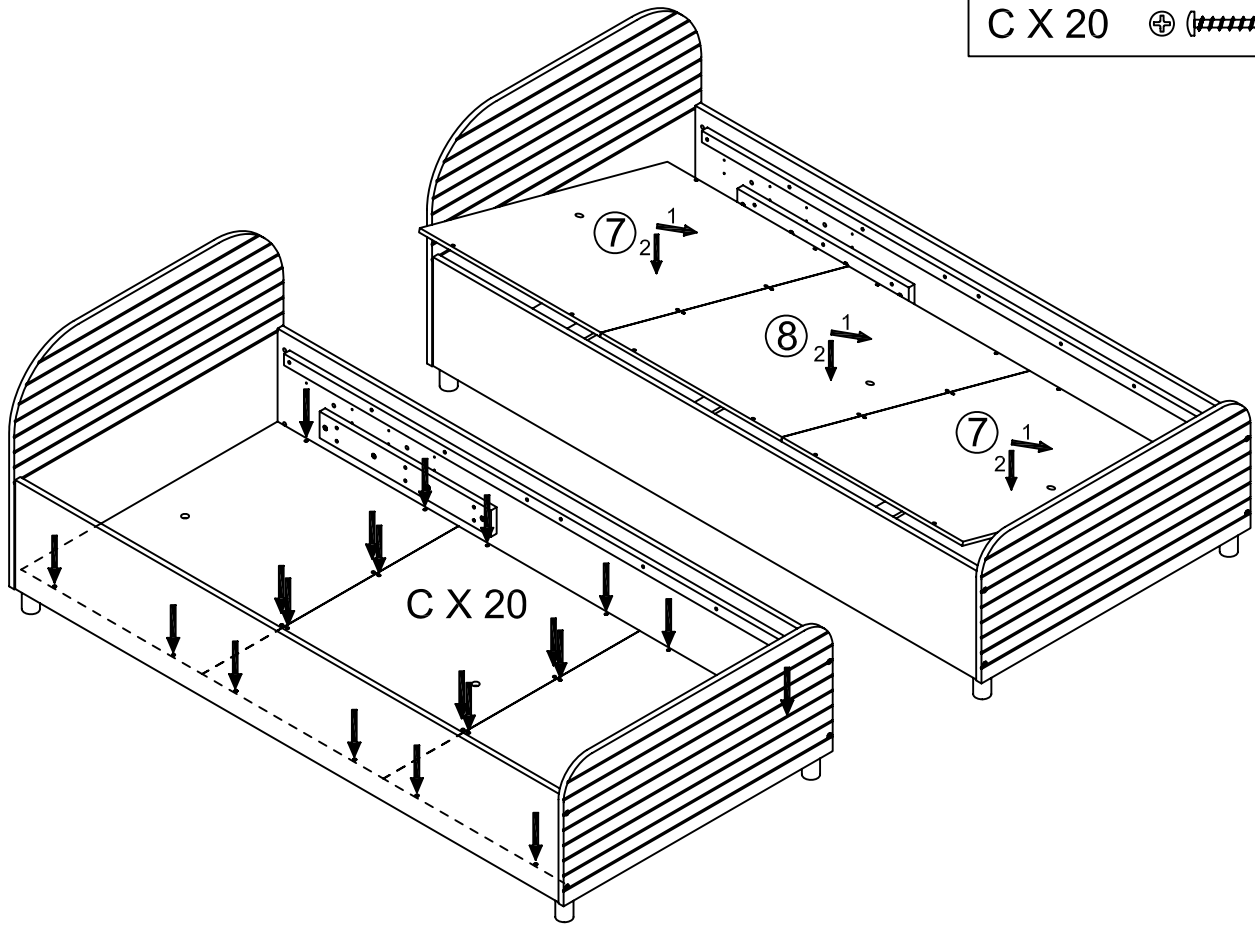

8

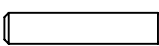
J X 12 

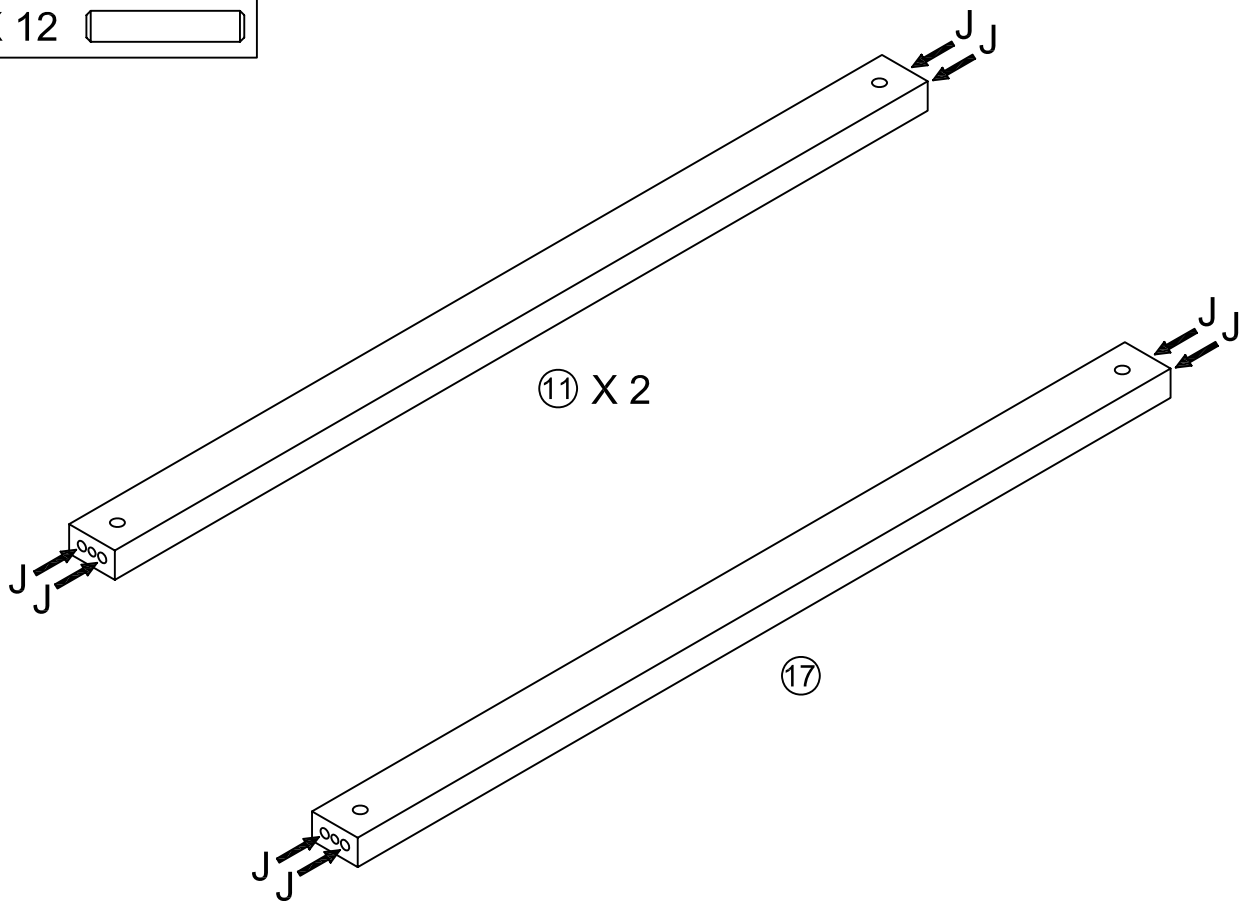

9

D X 6 

G X 6 

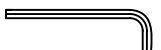
I X 1 

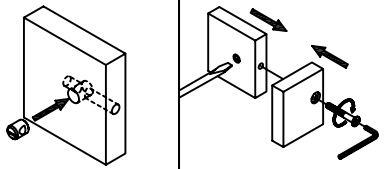
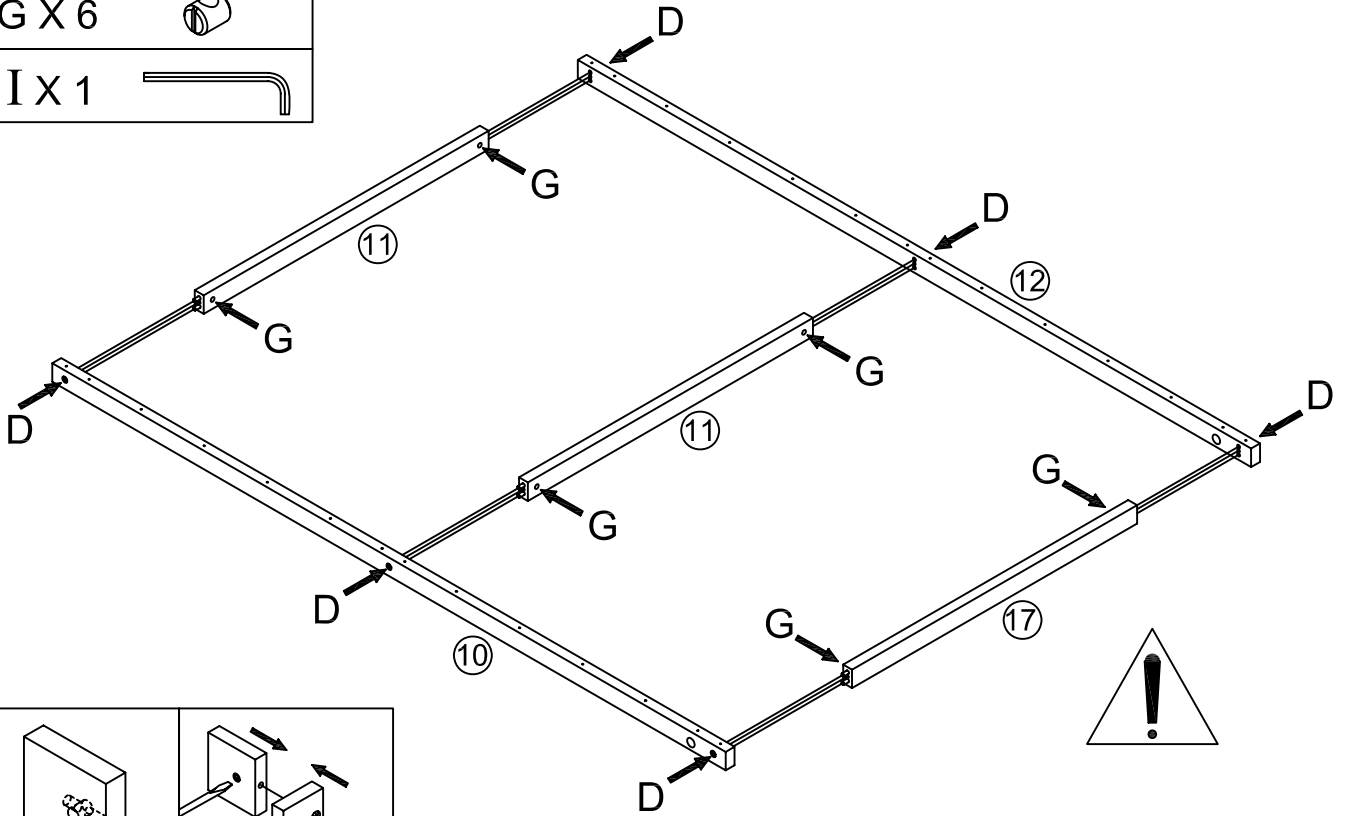

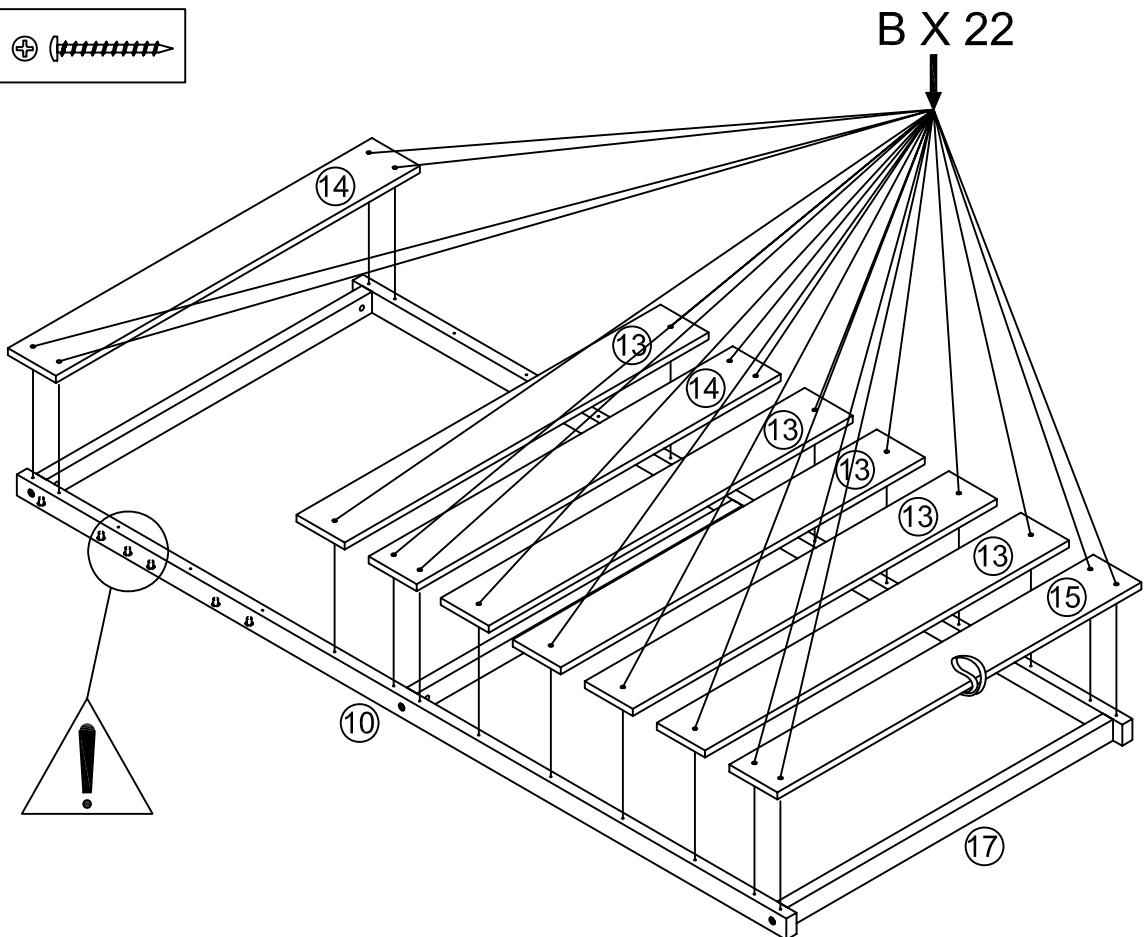

10

B X 22 

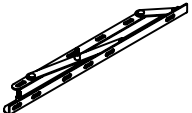
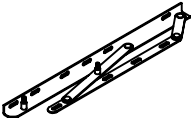

11

FX 4 	LX 1 	MX 1 
HX 2 		
PX 1 		

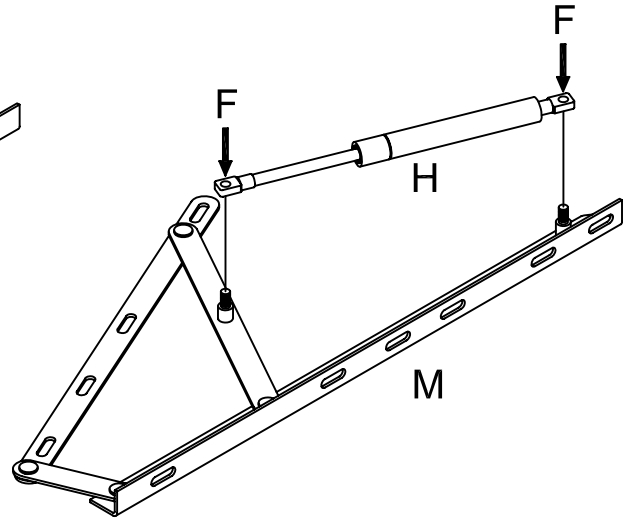
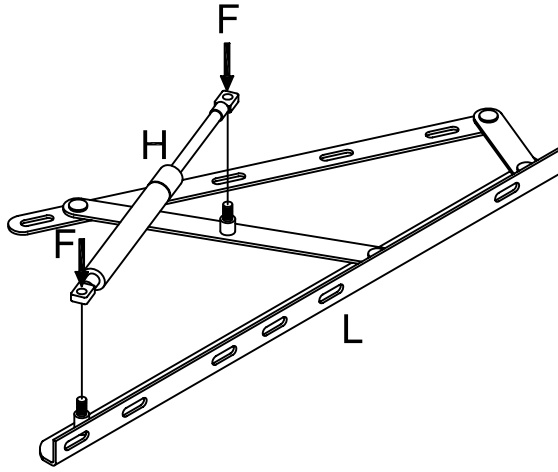
**12**

KX 12 

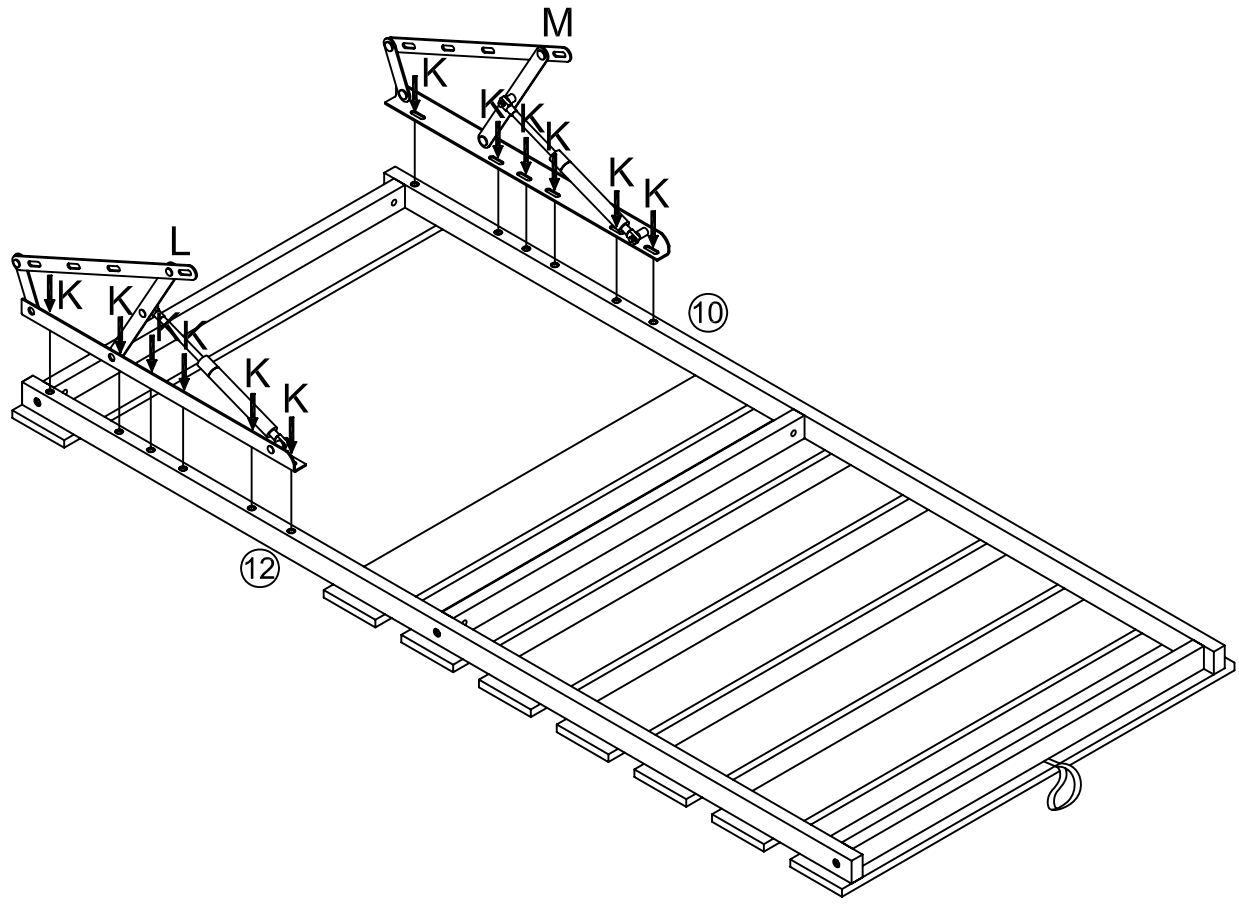

13

K X 8

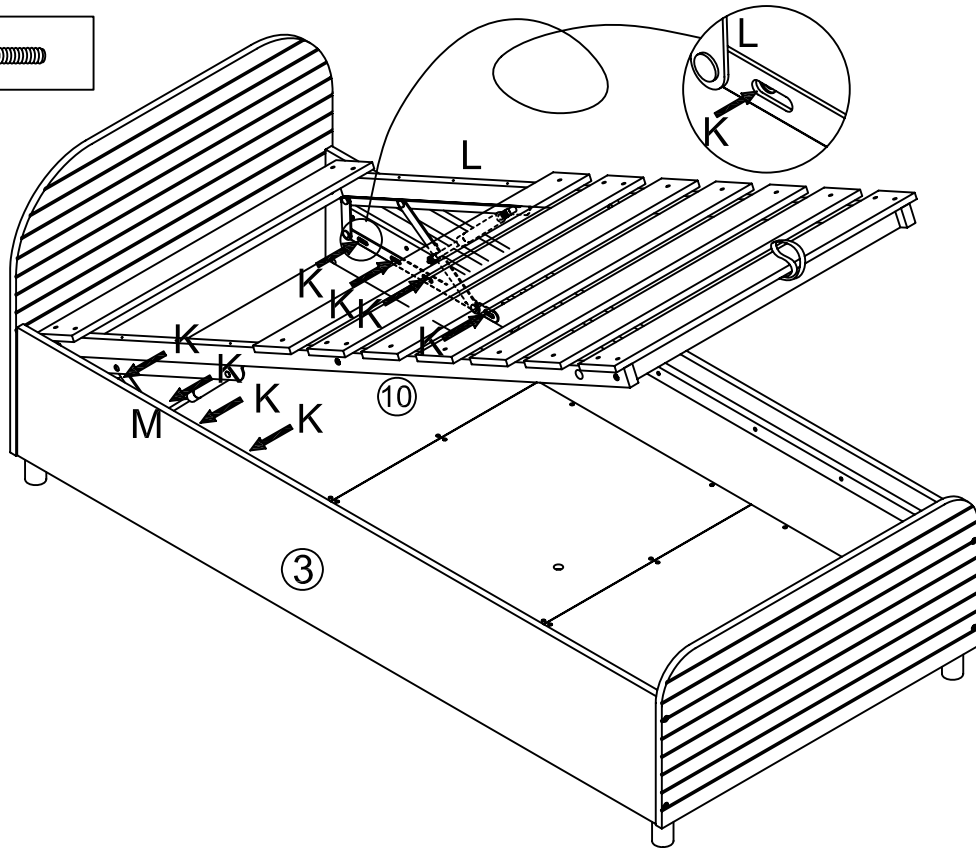
**14**

ATTENTION : Lors de la première descente du sommier, les vérins sont souvent très durs.
 WARNING: During the first descent of the bed base, the cylinders are often very hard.

ATENÇÃO: Quando a cama é baixada pela primeira vez, os cilindros costumam estar muito duros.
 ADVERTENCIA: La primera vez que se baja el somier, los cilindros suelen estar muy duros.

ACHTUNG: Beim ersten Absenken des Bettrahmens sind die Zylinder häufig schwergängig.
 ATTENZIONE: quando si abbassa la rete per la prima volta, i cilindri potrebbero essere molto duri.

OPGELET: Wanneer de lattenbodem voor de eerste keer omlaag wordt gebracht, zijn de cilinders vaak zeer hard.

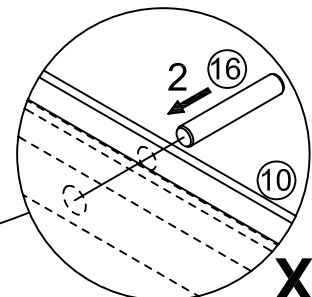
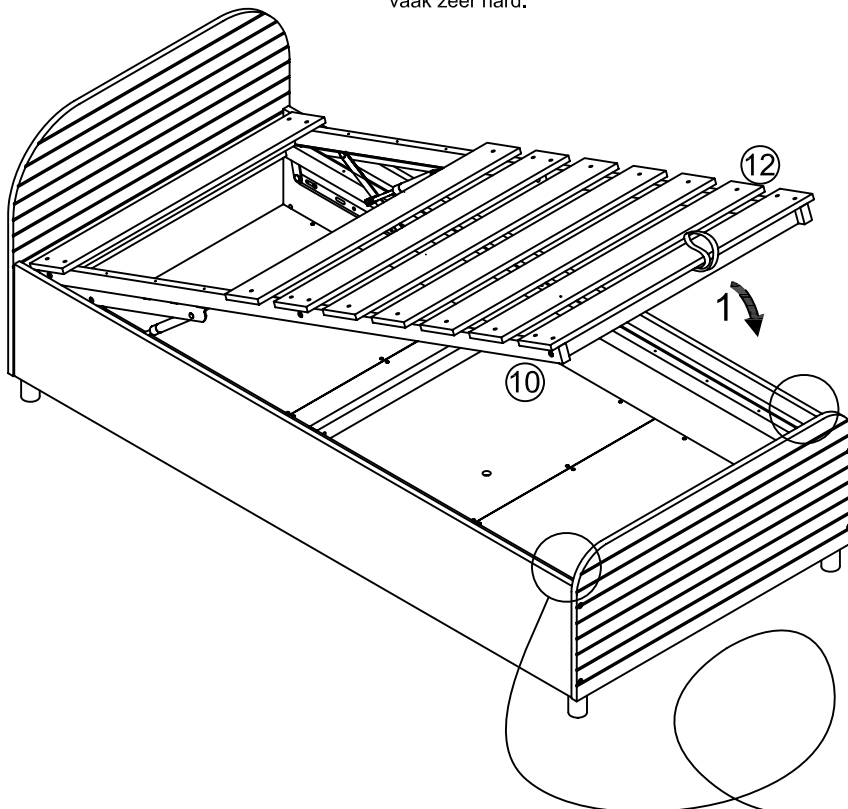
**X 2**

15

B X 6 

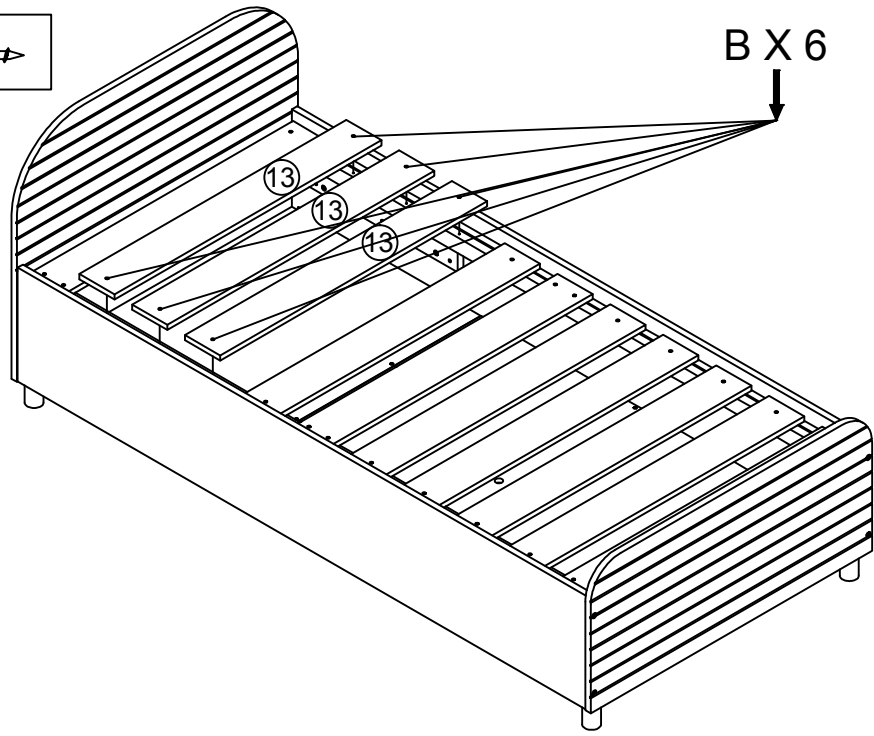

16

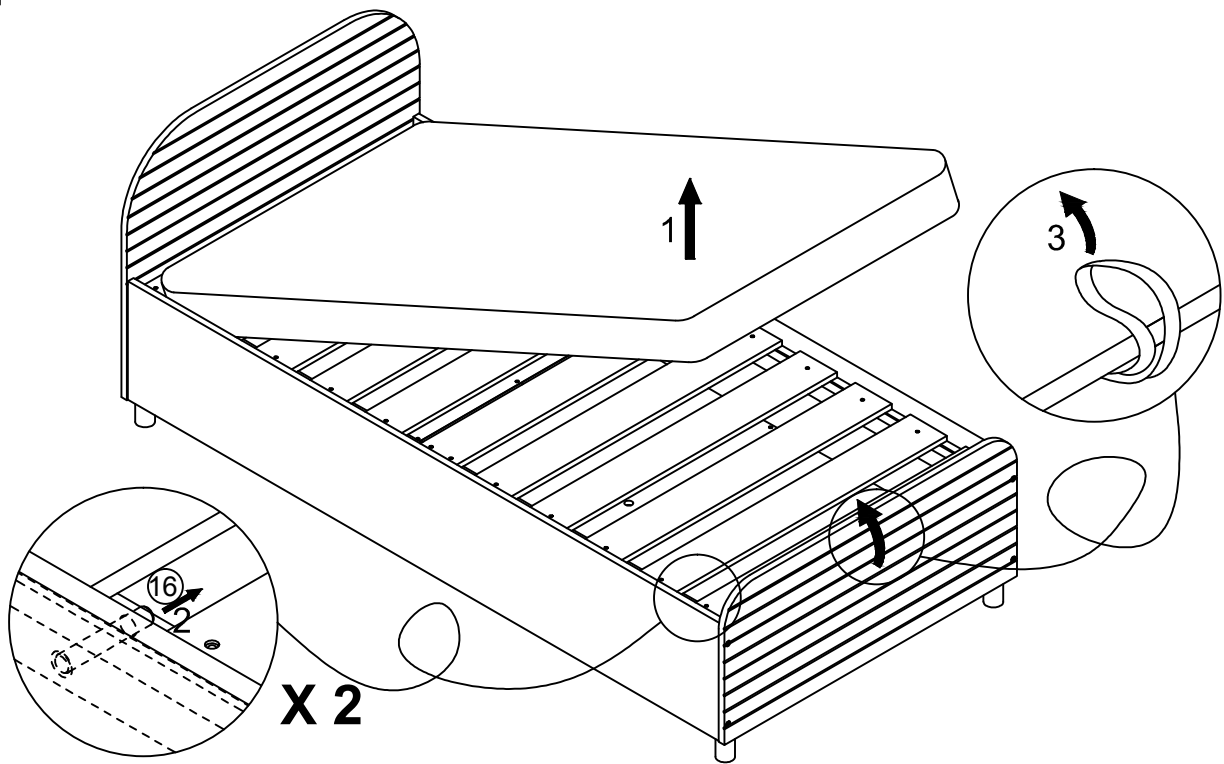

FR - Importé par / EN - Imported by / PT - Importado por / ES - Importado por / DE - Importiert von / IT - Importato da / NL - Geïmporteerd door :

UE/EU : Vertbaudet SAS - 36 avenue Alfred Lefrançois, 59200 Tourcoing, France

UK: Vertbaudet UK Limited - Elder House, St Georges Business Park, 207 Brooklands Road, Weybridge, Surrey KT13 0TS

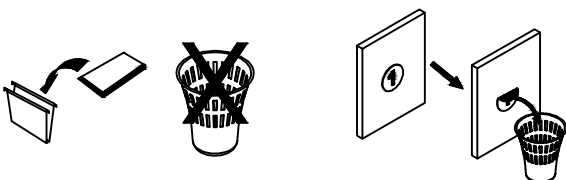

FR - Conserver la clé de montage pour resserrer régulièrement les assemblages afin de donner à votre meuble une stabilité permanente

EN - Keep the assembly spanner to tighten the screws from time to time in order to give permanent stability to your piece of furniture

PT - Conserve a chave de montagem para apertar regularmente as ligações de modo a que o seu movel mantenha uma estabilidade permanente

ES - Conservar la llave de montaje para reforzar regularmente los acoplamientos, con el propósito de ofrecer a su mueble una fijeza permanente.

DE - Den Montageschlüssel aufbewahren, um die Verbindungen regelmässig nachzuziehen, damit Ihr Möbel stabil bleibt

IT - Conservare la chiave di assemblaggio per stringere le viti e garantire la costante stabilità del mobile

NL - De montagesleutel bewaren om de bevestigingen regelmatig vast te draaien. Zo is uw meubel altijd stevig

